

MAIN DATA:		LIFEBOAT SPECIFICATION:	
THE SHIP TO BE RESCUED IN	MD	MARK:	UMOE SCHAT-HARDING A/S
CERTIFICATE	MD	TYPE	22700
NO. REG. NUMBER	MD	WEIGHT OF BOAT WITH EQUIPMENT (MT)	2050 kg
YARD/OWNER	W / **	WEIGHT OF PERSONS (LOAD)	2200 kg
DAVT MAIN DATA:		TOTAL LIFTING WEIGHT (MT)	5350 kg
PROTOTYPE APPROVED LOAD	W 7000 kg	MAX HOISTING WEIGHT (MT)	3265 kg
APPROX. TOTAL WEIGHT OF ONE SET OF DAVITS BY WINCH (CALCULATED WEIGHT)	4300 kg *	MAIN DIMENSIONS (mm x mm x m) 8500 x 2250 x 2550 mm	
* Cyl. wärmsugspärring och bordsgästform			

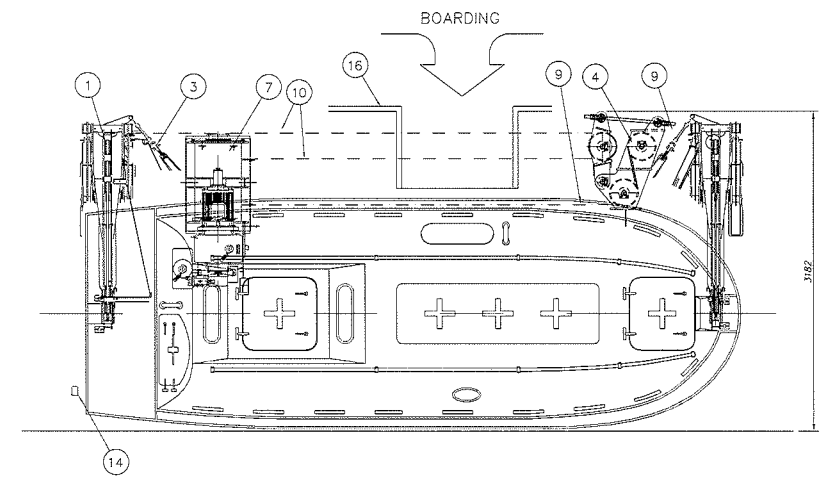
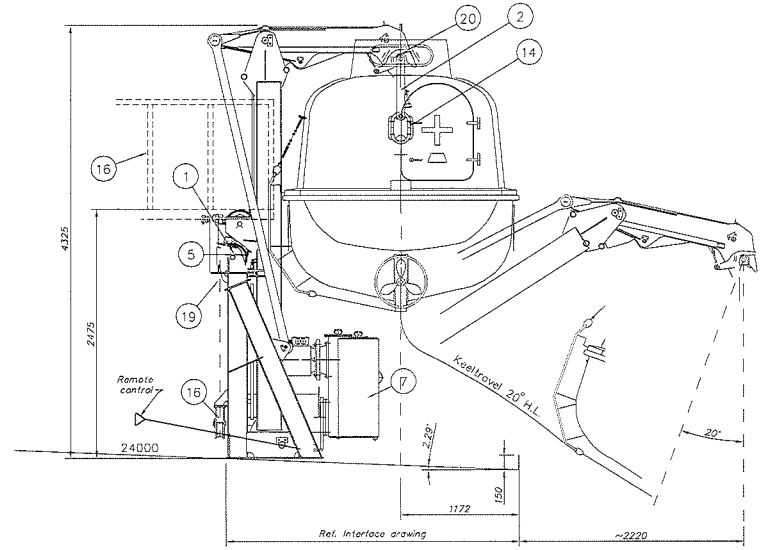
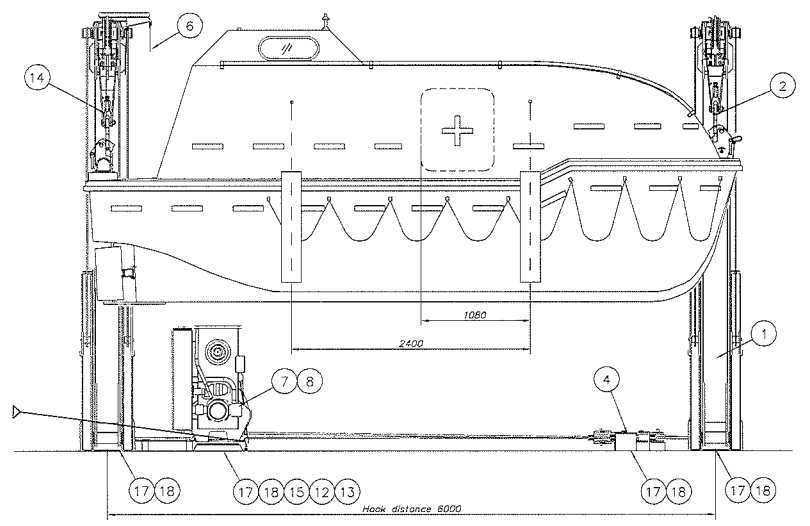

○ = Equipment delivered with certificate.
 X = Yard supply. Not included in standard delivery from UMOE SCHAT-HARDING AS

NOTE:
 See item 17 & 18 for dimensions and reaction forces.

SW	SL	IL	Item no.	Description	Material	Art. no.	Remarks	kg pr. unit
○			20	HANGING OFF	SET	NB3209		
			19	Safety pin		NB4064		
			18	Footprint and reaction forces		N73716		
			17	Interface drawing		NB5736		
X			16	Boarding platform				
			15	Winch foundation		NB3964		
			14	Link		NE0411		
			13	Hex nut M30	Galv B	0230.06359	DIN934	
			12	Hex head screw M30x90	Galv B.8	0202.42309	DIN931	
			11					
○	34.3	205.8	10	Fall wire aft Notar HP Ø18 L = 50m		0170.20529		
○	34.3	205.8	9	Fall wire fore Notar HP Ø18 L = 47m		0170.20529		
			8	EL diagram		2054081-N75332		
○	See winch doc.		7	Winch W 80 R		NB3194		
			6	Remote control arr.		NB3321		
			5	Limit switch arr.		NB3637		
			4	Adjustable sheavehouse		NB5537		
			3	Lashing arrangement		NB3357		
○	34.3	205.8	2	Link Forward		N94088		
○	34.7	154.5	1	Davit assembly		NB3292		

* Each davitstand

This drawing is the property of Umoë Schat-Harding AS. It may not be copied, altered or made available to others without our written permission.

Checked by: 01.03.05
 Approved by: MB
 Scale: 1:25

VIP 700/22 TECB/W80R
 General Arrangement
 Samsung 1556/57

SCHAT HARDING

Replacement for: NB3080 G

H-8-1-①



East China Shipbuilding
Institute Factory

**DECLARATION OF
CONFORMITY**

N°: 4185 CHN2005

as per Module D (E) of the European Union Council Marine Equipment Directive (MED) 96/98 EC,
as amended by the Commission Directive 98/85 EC

The undersigned Company certifies that the sets of equipment specified below have been manufactured and tested as required by the provisions of the Directive 96/98 CE on Marine Equipment and are in accordance with the Regulations, Codes or Standards stated on the CE Type Approval Certificate (EC Type Examination Certificate - Module B).

N° 06573/B0 EC dated 22/06/2004 valid until 22/06/2009

issued by Bureau Veritas notified for the purpose of the Directive under number 0062

This Declaration of Conformity is issued within the scope of the Works Approval N° SMS.W.L.CE.D/3185/B.0 which authorizes the Manufacturer to affix the CE  marine mark and the Notified Body number to the related equipment.

PURCHASER:

Order N° :

Intended for: For Stock

Ship's Name:

EQUIPMENT:

Item: A.1/1_36 Lifeboat Propulsion Engine

Description : Type : 380J-3

3 Cylinder in line Four Stroke, Single action Diesel Engine ;Bore× Stroke : 80×90mm

Engine output/Engine speed : 20.6kw/2800rpm

Propeller input/Propeller shaft speed: 19.7kw/1065rpm.

Gearbox : ZF12M2.63:1

Quantity: 1 set

Serial Number(s): 05724 /Diesel engine Set & 25734 /Gearbox

Date of manufacture: 2005/9.

Date of peremption (where relevant) :

Marking and stamping:  0062/05

(As per para. 9 to Schedule of Approval)

SIGNED ON BEHALF OF THE MANUFACTURER

Name : Zhu Dong Chang

Position : chief engineer

Place & date: PR China/ 2005/9/10

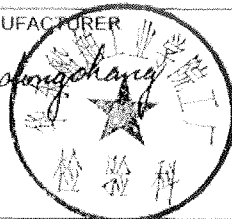

**BUREAU
VERITAS**
MARINE DIVISION

Authorization N°
SMS.W.L.CE.D/3185/B.0

Any person not a party to the contract pursuant to which this document is delivered may not assert a claim against BUREAU VERITAS for any liability arising out of errors or omissions which may be contained in said document, or for errors of judgment, fault or negligence committed by personnel of the Society or its Agents in the establishment or issuance of this document, and in connection with any activities for which it may provide. The latest published Marine Division General Conditions are applicable.

BUREAU VERITAS Head Office: 17 bis, Place des Reflets - La Defense 2 - 92400 COURBEVOIE - Tel : 33 (0)1 42 91 52 91 - Fax : 33 (0)1 42 91 28 94
AdME 1528

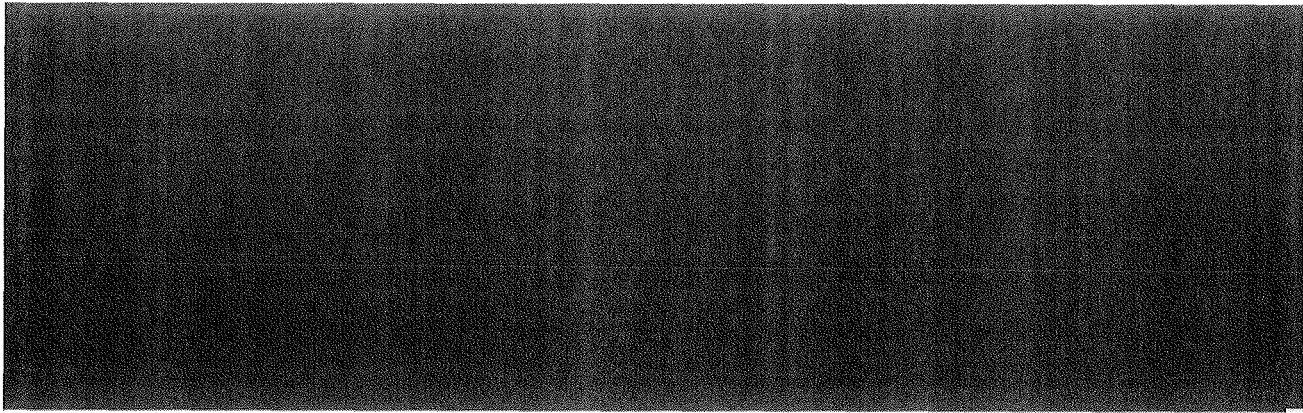

Continuation sheet of Certificate N°: 5672CHN05

For BUREAU VERITAS



M-8-1-5

BUREAU VERITAS S.A. is designated by the French Maritime Authority as a "notified body" under the terms of the French Regulations Division 140 Chapter 140-2. This certificate is issued within the scope of the General Conditions of BUREAU VERITAS Marine Division. Any Person not a party to the contract pursuant to which this document is delivered may not assert a claim against BUREAU VERITAS for any liability arising out of errors or omissions which may be contained in said document, or for errors of judgement, fault or negligence committed by personnel of the Society or of its Agents in establishment or issuance of this document, and in connection with any activities for which it may provide.

<http://www.veritainb.com/veritainb/jsp/certificate.jsp?id=1163308165>

BV Mod. AdE 1527- 09/2004



MARINE DIVISION

**BUREAU
VERITAS**

Notified Body N° 0062

Certificate N°: 5673CHN05

H-8-1-(6)



CERTIFICATE OF CONFORMITY

as per Module G of
European Union Council Directive
96/98/EC of 20 December 1996 on Marine equipment as amended

This certificate is issued under the French Maritime Authority to:

Umoe Schat-Harding Boatbuilding (Qingdao) Co. Ltd.
Qingdao - CHINA

to attest that appropriate examinations and tests have been carried out, in the presence of BUREAU VERITAS, to check that the product detailed below complies with the relevant requirements of the Council Directive 96/98/EC of 20 December 1996 last amended by Commission Directive 2002/75/EC of 2 September 2002, and the type as described in the EC type-examination certificate mentioned below:

EC item number and designation:

A.1/1.17 - LIFEBOATS

Quantity	: 1 set
Description	: Totally enclosed lifeboat/rescue boat,type:22TECB
EC Type-examination Certificate	: 11596/A0 EC
Type	: 22TECB
Type of launching system	: Davit
Number of persons	: 30/6 (Lifeboat/Rescue boat)
TE (Totally enclosed) PE (Partially enclosed) O (Open)	: TE
Fire protection	: Tanker Version
Material	: FRP
Length/Breath/Depth (m)	: 6.50 x 2.30 x 1.20
EC Type Examination Certificate (Nr, date, issued by)	: 11596/ A0 EC by BV(EC) on 24/04/2002
Piece / Serial number(s)	: 1set/22-05-155
Engine type/serial no	: 380J-3/05724
Total load on davit(fully+persons)	: 5260Kg(lifeboat)/3460Kg(rescue boat)

List of attached documents:

This certificate authorizes Umoe Schat-Harding Boatbuilding (Qingdao) Co. Ltd. to affix the "mark of conformity" (wheelmark) to the product detailed herein.

Mark(s) and identification affixed



0062/ 05

Last inspection date : 31 Oct 2005
Surveyor : Jennifer Zhang

Issued on : 04 Nov 2005
Local office : BV SHANGHAI

BUREAU VERITAS S.A. is designated by the French Maritime Authority as a "notified body" under the terms of the French Regulations Division 140 Chapter 140-2. This certificate is issued within the scope of the General Conditions of BUREAU VERITAS Marine Division. Any Person not a party to the contract pursuant to which this document is delivered may not assert a claim against BUREAU VERITAS for any liability arising out of errors or omissions which may be contained in said document, or for errors of judgement, fault or negligence committed by personnel of the Society or of its Agents in establishment or issuance of this document, and in connection with any activities for which it may provide.

<http://www.veristamb.com/veristamb/jsp/certificate.jsp?id=201691125>

BV Mod. AdE 1527- 09/2004

Continuation sheet of Certificate N°: 5673CHN05

For BUREAU VERITAS



H-8-1-①

BUREAU VERITAS S.A. is designated by the French Maritime Authority as a "notified body" under the terms of the French Regulations Division 140 Chapter 140-2. This certificate is issued within the scope of the General Conditions of BUREAU VERITAS Marine Division. Any Person not a party to the contract pursuant to which this document is delivered may not assert a claim against BUREAU VERITAS for any liability arising out of errors or omissions which may be contained in said document, or for errors of judgement, fault or negligence committed by personnel of the Society or of its Agents in establishment or issuance of this document, and in connection with any activities for which it may provide.