

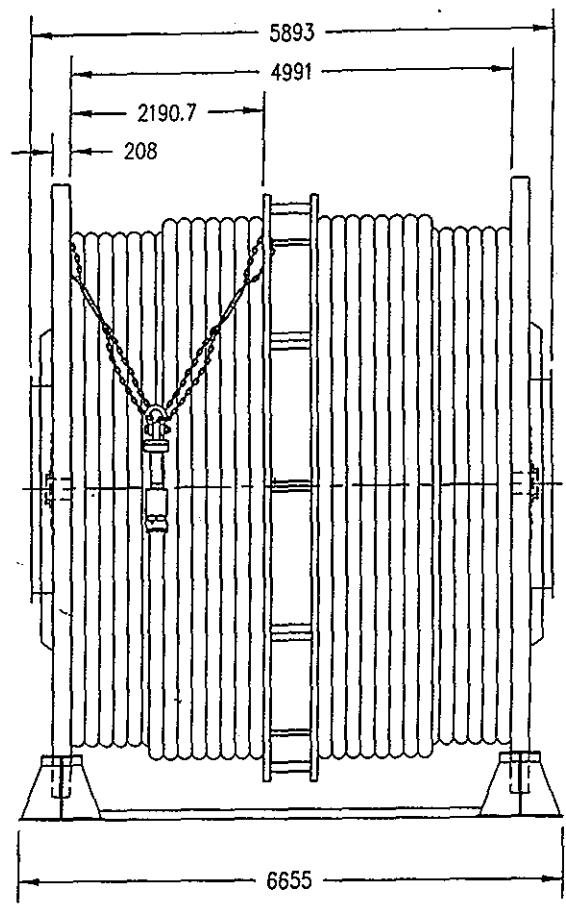

METRIC

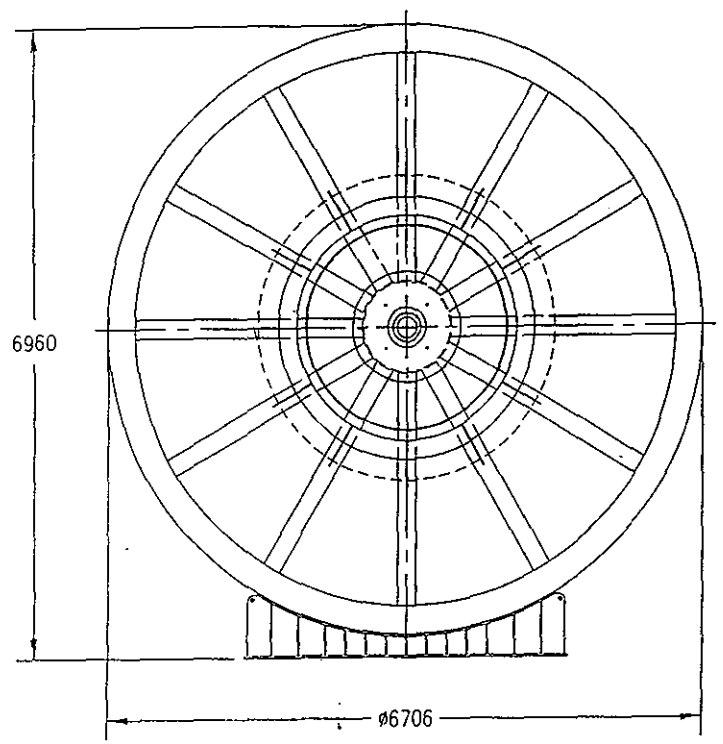

Contract
#C94711

Section#13

	CLIENT:	A/S NORSKE SHELL - Troll Field Development	PROJECT:	A648
	DOCUMENT:	Design, Fabrication and Installation Resume - WSC Doc. No. A648E007	DATE:	03/10/95
	TITLE:	Ø7.7M Reel Configuration with Ø3.35M Drum.	FILE:	A648-027
			FIGURE NO.:	4-5

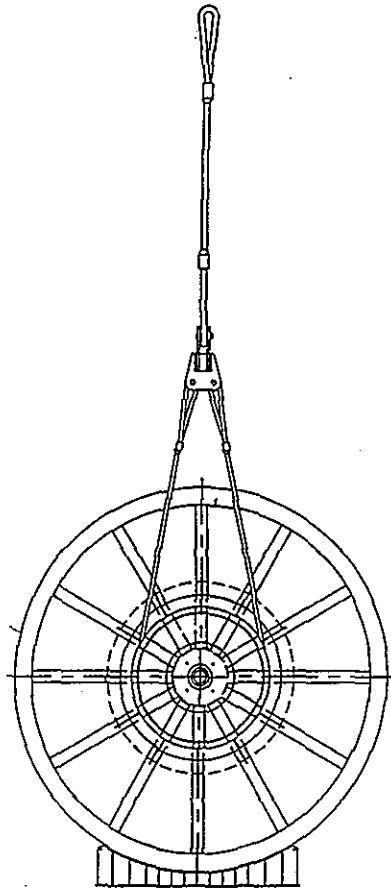
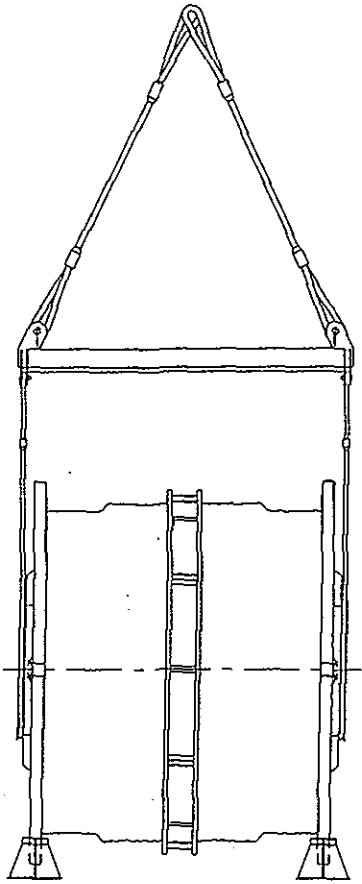

WEIGHT OF SPREADER BAR WITH SLINGS; 3.00 TONNES.



Wellstream

CLIENT:	A/S NORSKE SHELL – Troll Field Development	PROJECT:	A648
DOCUMENT:	Design, Fabrication and Installation Resume – WSC Doc. No. A648E007	DATE:	03/10/95
TITLE:	Typical Spreader Bar Lifting Configuration.	FILE:	A648-028
		FIGURE NO.:	4-6

Contract
#C94771

Section#13